

Q·connect™ MANUAL

The Q-connect is designed to allow tree injection treatments to be performed quickly, safely, and accurately. Be certain to read ALL instructions before use. Refer to the appropriate product guide and product label for dosage and mixing instructions.



For tech support and protocols call **1-877-272-6747**
www.treecarescience.com • info@treecarescience.com



Patent Pending



Digital Download of this Manual Available at: www.treecarescience.com/q-connect



Q-CONNECT OVERVIEW | 1

INSTRUCTIONS FOR USE | 2-5

 PHASE 1 - GETTING SET UP | 2

 PHASE 2 - DRILLING INJECTION SITES | 3

 PHASE 3 - INJECTING | 3-4

 PHASE 4 - CLEANING | 4-5

GENERAL CARE & STORAGE | 6

APPROVED PRODUCTS LIST | 6

TROUBLESHOOTING | 7-8

MAINTENANCE | 8-9

REPAIR INSTRUCTIONS | 10-13

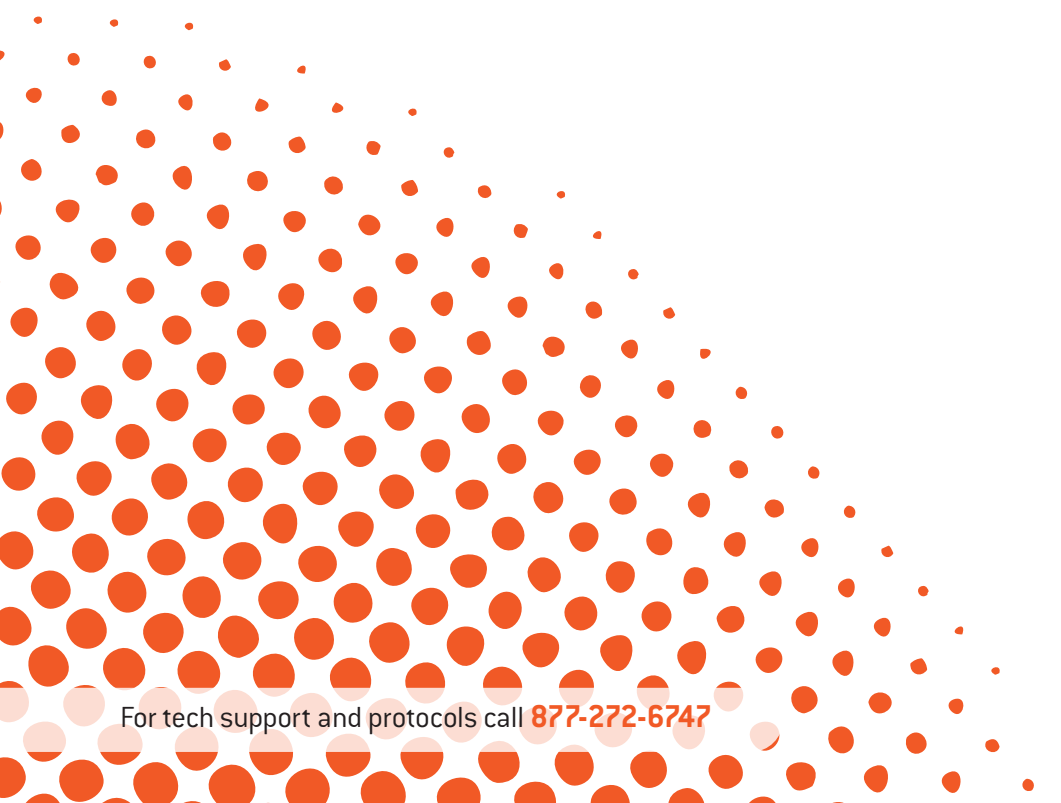

BOTTLE CAP ASSEMBLY (top view)

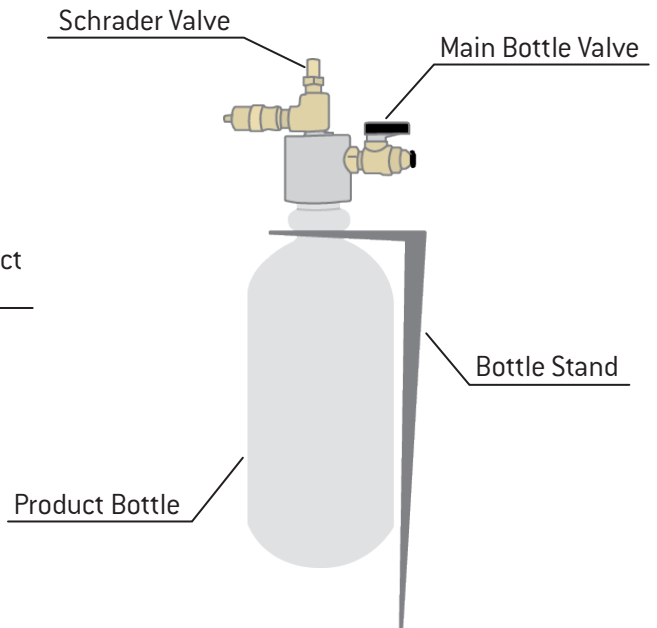
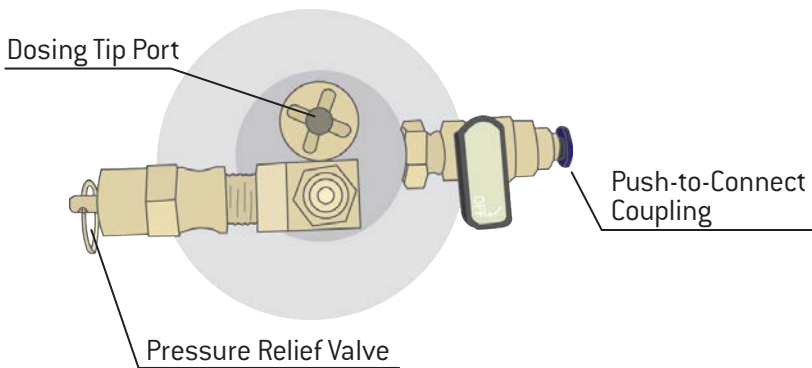

HARNESS

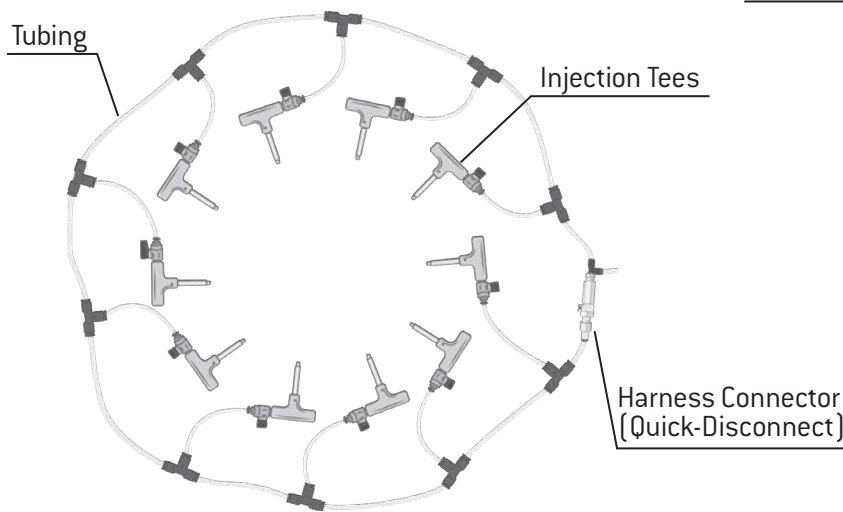

INJECTION PORT

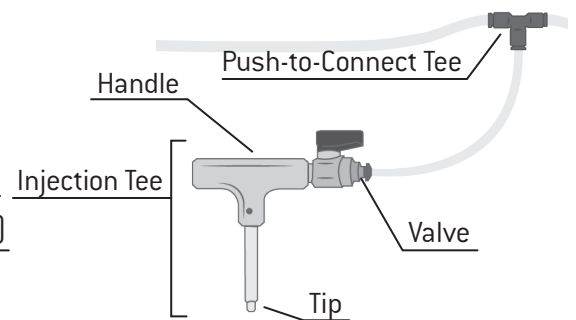

EQUIPMENT CHECKLIST:

Included:

- Bottle Cap Assembly
- Q-connect Tees & Tubing
- Product Bottle
- 15/64" High Helix Drill Bits
- Bottle Stand
- Carrying Bag & Insert
- Manual
- 3' of 5/32" Replacement Tubing

- Extra Grommet 
- Extra Duckbill Valve 
- Rubber Valve Plug 

You Will Need:

- Bike/Foot Pump
- Electric Drill - 18v Recommended
- DBH Measuring Tape
- Proper PPE (Refer to product label)
- Q-connect Field Repair Kit (Recommended)

I. GETTING SET UP

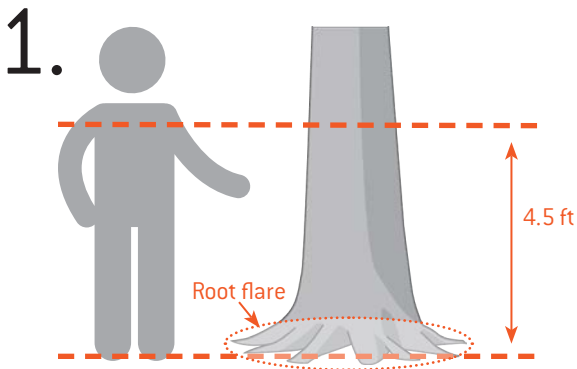

1. Measure the tree's Diameter at Breast Height (DBH)

NOTE: Breast height is commonly measured 4.5 feet above soil grade.



2. Refer to the product label and measure the required dose.

NOTE: Be sure to wear appropriate personal protective equipment (PPE) - refer to the label for required PPE.



3. Insert the bottle stand into the ground to support the bottle.

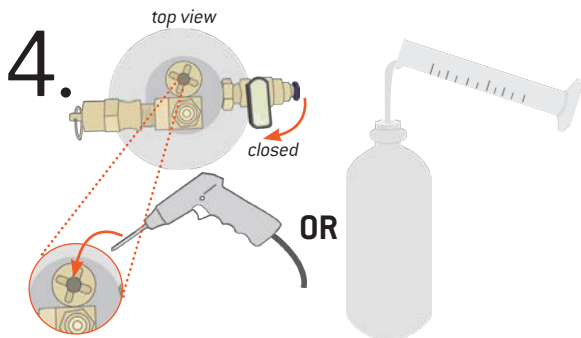

4. With the main bottle valve closed, unscrew the bottle top and pour the measured product dose into the bottle, OR use the Q-gun or iQ-infuser to dose the bottle directly through the dosing port.

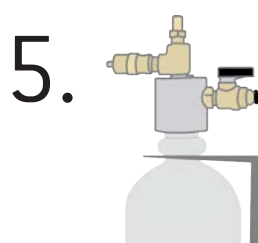

5. Ensure that the bottle cap is screwed on securely to seal the bottle and cap.

NOTE: Take care to avoid cross-threading the cap and bottle. Turning the cap counterclockwise first may help align the threads before turning clockwise to tighten on the cap.

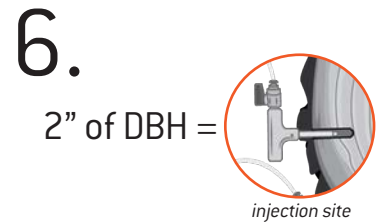

6. Determine the number of injection sites needed for the application.

NOTE: Use ONE injection site for every TWO inches of tree diameter.

of injection sites = $\frac{DBH}{2}$
Example: 12" tree = 6 injection sites

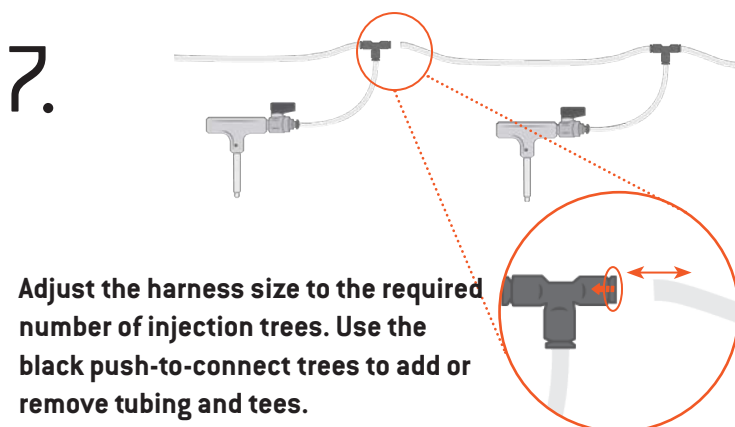

7. Adjust the harness size to the required number of injection trees. Use the black push-to-connect tees to add or remove tubing and tees.

NOTE: To use a push-to-connect, press and hold down the plastic collet and pull out the tubing.

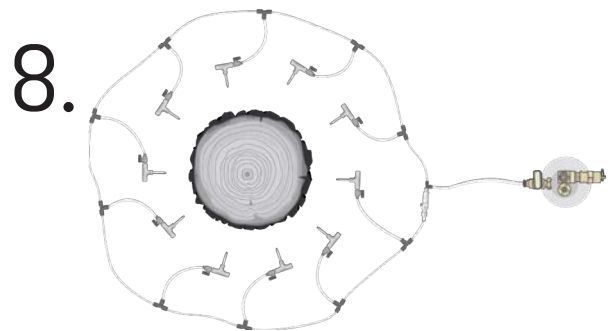

8. Lay the Q-connect harness around the base of the tree. Ensure both ends of the harness are connected (connector should "click") and the harness is connected to the bottle.

II. DRILLING INJECTION SITES

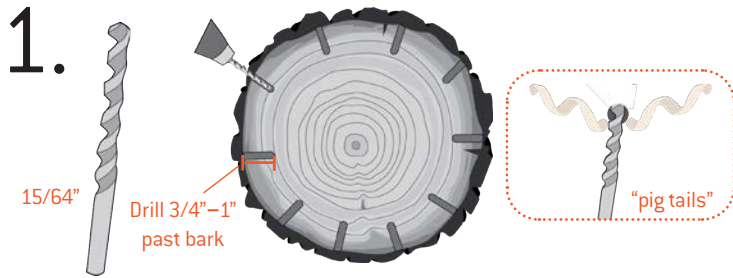

Drill injection holes using a 15/64" high helix drill bit. Drill into the root flares, 3/4" - 1" past the bark, and perpendicular to the bark surface.

NOTE: Replace drill bits every 5-10 trees. A sharp drill bit should produce "pig tails".

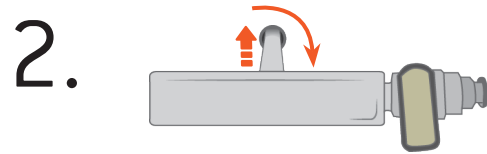

With the tee valve closed, insert the injection tip securely into the hole. Ensure a tight seal with a slight clockwise twist.

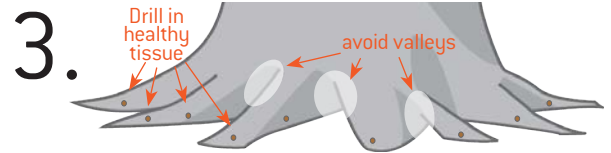

Space injection sites evenly around the tree, avoiding deadwood, decay, and valleys between root flares.

III. INJECTING

Before beginning injection applications, be sure to wear appropriate personal protective equipment (PPE) as specified on the product label. Always wear eye protection when working with substances under pres-

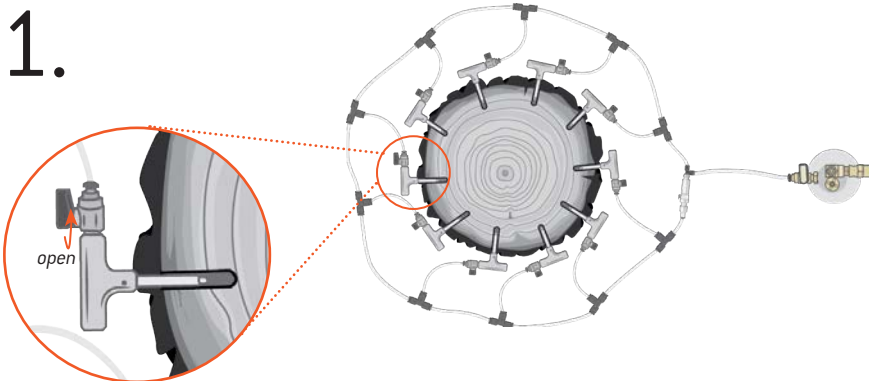

Open the valve on the tee farthest from the bottle.

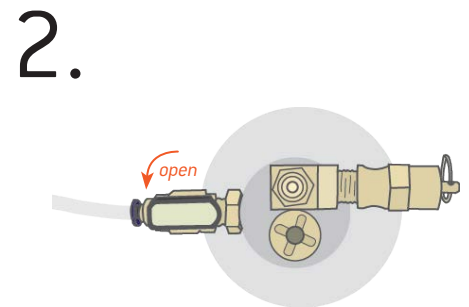

Open the main bottle valve.

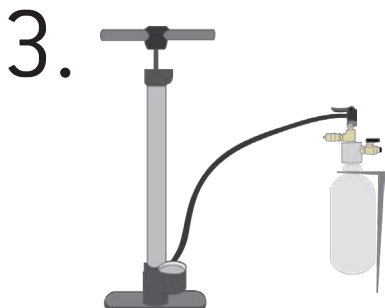

Attach the bike pump to the bottle cap Schrader valve.

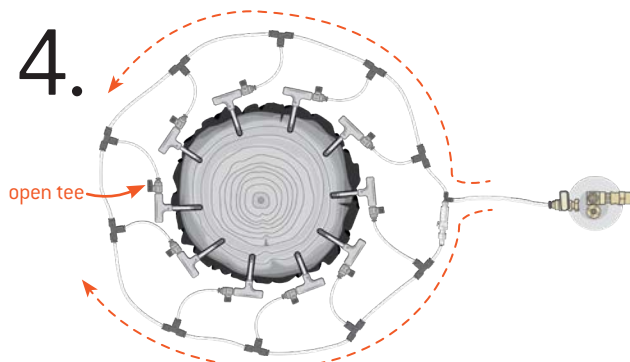

Pressurize the bottle with several pumps to prime the lines (15-25 psi). The open tee will help draw product evenly through the harness.



III. INJECTING *(continued)*

5.

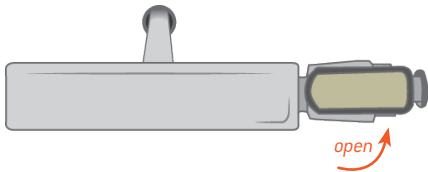

Once primed at low pressure, open all injection tee valves.

NOTE: Inspect the tees and tubing for leaks or blockages before continuing.

6.

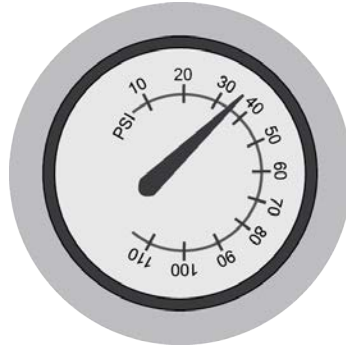

Pressurize the bottle to 35 psi. If more pressure is needed, the bottle can be pressurized up to 55 psi.

NOTE: The pressure relief valve will release pressure at 60 psi.

7.

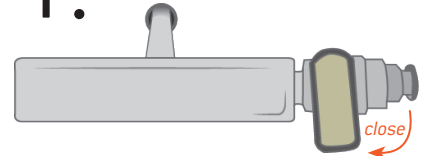

Once the harness and tees are empty, close all injection tee valves.

NOTE: Residual product in the tees may need additional time to move into the tree once the lines appear empty. It is recommended to wait a few minutes after the lines appear clear to remove the injection tees.

8.

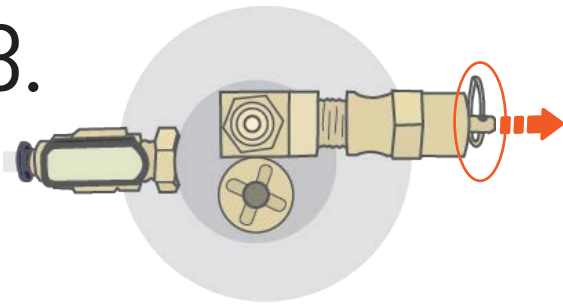

Slowly and carefully use the pressure relief valve on the bottle cap to depressurize the bottle.

9.

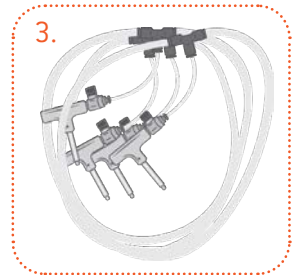
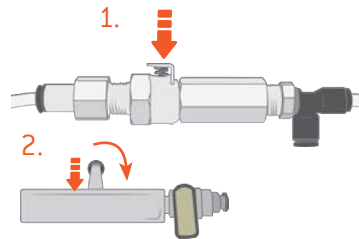

Press the quick-disconnect button to release the harness connector *(figure 1)*. Remove each injection tee with another slight clockwise turn while pulling it out *(figure 2)*.

NOTE: For easy carrying, remove tees one-by-one around the tree, holding every other black push-to-connect tee while coiling the harness *(figure 3)*.

IV. CLEANING

1.

Ensure that the bottle and harness lines are empty.

2.

70% isopropyl alcohol



+

Water

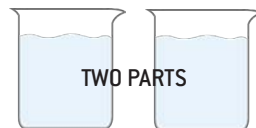

=

Cleaning Solution

Fill the bottle 1/3 to 1/2 way with a dilute isopropyl alcohol cleaning solution. To make a cleaning solution, mix ONE (1) part 70% isopropyl alcohol to TWO (2) parts water.

NOTE: For 90% isopropyl alcohol, mix ONE (1) part alcohol to THREE (3) parts water.

3.

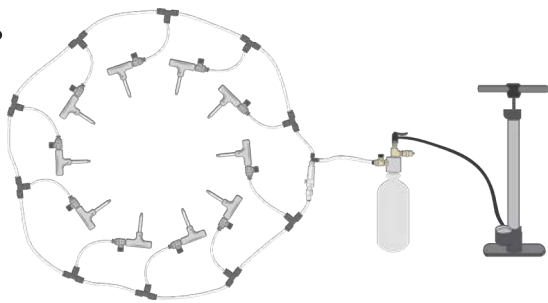

Screw on the bottle cap. With the harness connected and the injection tee valves closed, pressurize the bottle with a bike pump to 40 psi.

4.



One at a time, open the injection tee valves over a rinsate collection container (such as a bucket with lid or empty injection bottle) to allow cleaning solution to flow through each tip.

NOTE: The bottle may need to be re-pressurized during the process.

5.



Once the bottle and harness are empty of cleaning solution, pressurize the harness with air to flush any remaining fluid into the waste container. Dispose of pesticide wastes and rinsate in accordance with the product label and local, state, and federal regulations.

NOTE: It is recommended to flush the system with water after the cleaning solution, particularly before storage.

6.

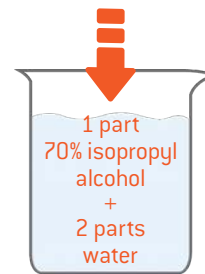

Thoroughly clean the harness connector, pressure relief valve, and other components as needed. It is recommended to remove and soak the harness connector in cleaning solution after heavy use.

7.

See **MAINTENANCE & REPAIR** (page 8) for further cleaning instructions.

8.



Always store the Q-connect system clean and dry.

- Purge all fluid from the lines after each use and prior to changing chemistries.
- It is recommended that you clean your Q-connect after every day of use with a dilute isopropyl alcohol solution (1 part 70% isopropyl alcohol to 2 parts water).
- It is recommended to run water through the unit after the cleaning solution, and allow the lines to dry completely before storage.
- Thoroughly clean bottle cap, pressure relief valve, and harness connector weekly or after heavy use.
- Store your Q-connect in a dry area free from dust and particulate matter.
- Store above 32°F (0°C) and below 110°F (43°C).

APPROVED PRODUCT LIST

The Q-connect is a versatile workhorse for your tree injection plans. We are actively engaged in research to broaden the usefulness of this tool. Refer to our website for a list of approved products.

Approved Product List website link:

www.treecarescience.com/q-connect

Refer to the table below to troubleshoot the Q-connect system.

| SYMPTOM | POSSIBLE PROBLEM | SOLUTION |
|---|---|--|
| The bottle cannot be pressurized or does not hold pressure | Improper seal between bike pump and Schrader valve | Re-attach the bike pump securely |
| | Faulty or damaged bike pump | Replace |
| | Faulty or damaged Schrader valve | Repair or replace Schrader valve |
| | Main bottle valve is open, with tubing disconnected | Ensure the harness tubing is connected to the bottle cap |
| Hissing/leaking sound when bottle is pressurized* <i>*Depressurize the system before attempting repairs</i> | Bottle top not securely threaded onto bottle | Remove and re-attach bottle top assembly to bottle |
| | Improper seal between bike pump and Schrader valve | Re-attach the bike pump securely |
| | Duckbill valve is damaged or worn | Clean duckbill valve, replace duckbill valve, or plug valve with rubber valve plug |
| | Leaking Schrader valve | Clean or replace valve stem |
| | Leaking seal or connection between bottle top components | Call our Solution Center for technical support: 877-272-6747 |
| The black push-to-connect tee is leaking | Tubing only partially inserted | Push tubing in farther |
| | Tubing has been scored too deeply | Restore end or replace tubing segment <i>(See Repair Instructions Section IV.)</i> |
| | Tubing may have been cut incorrectly | Re-cut end to ensure straight edge, or replace tubing segment |
| | Damaged push-to-connect fitting | Replace push-to-connect tee |
| Tubing cannot be inserted into push-to-connect fitting | Obstruction in push-to-connect fitting | Inspect push-to-connect fitting for obstruction, such as a broken tubing end |
| | Hardened product residue is preventing push-to-connect function | Soak push-to-connect fitting or tee in cleaning solution to loosen residue |
| Harness connector will not snap together | Dirt/residue build-up | Thoroughly clean harness connectors |
| One injection tip will not inject | Bad injection site in tree | Try new injection site |
| | Plugged injection tip or handle | Clean injection tee components |
| | Pressure leak somewhere in the lines | Ensure that all injection tees are securely inserted into their injection sites and that no tees are leaking |
| Tip spins in handle (can't be tightened) | Handle threads are stripped | Replace injection tee handle |
| | Set screw is not properly tightened | Remove set screw and injection tip Replace and tighten the tip and set screw |



Troubleshooting continued...

| SYMPTOM | POSSIBLE PROBLEM | SOLUTION |
|---|---|---|
| Product pools in tubing during injection application | Competing pressure/resistance in system | Raise tubing with pooled product above the level of the surrounding tubing to allow product to be gravity-fed into the nearest injection port Close valves on empty injection tees. Open one valve to draw product into injection port |
| | Malfunctioning or worn-out harness connector | Replace, or bypass with black push-to-connect tee |
| Injection tee difficult to remove from injection site | Extremely tight seal between injection site and tip | Turn injection tee handle clockwise while smoothly pulling backward on the handle <i>NOTE: Turning counterclockwise can strip the handle threads.</i> |
| | | Lightly rock or jiggle tee handle side-to-side to break the seal <i>DO NOT TWIST: twisting back and forth may break the tip or strip the handle threads.</i> |

MAINTENANCE & REPAIR

Basic Maintenance

- Clean:** run cleaning solution through the unit after use
 - » keep pressure relief valve clean to prevent sticking
 - » always clean the unit with an isopropyl alcohol-based cleaning solution
1 part 70% isopropyl alcohol to 2 parts water
 - » recommended to follow cleaning solution with clean water
- Soak** major components weekly or after heavy use in an isopropyl alcohol-based cleaning solution
- Lubricate** O-rings on pressure relief valve and male barb of harness connector and X-ring on bottle cap as needed. *See Repair Instructions*
- Dry completely** before extended storage

Basic Maintenance Checklist

DAILY *(after use)*

- Clean harness, tees, bottle, and cap.
 - Clean pressure relief valve.
 - Clean duckbill valve if used for dosing.
 - Check tips for clogs.
 - Ensure harness connector is free from chemical residue and debris.
-

WEEKLY

- Soak harness connector (in an isopropyl alcohol-based cleaning solution).
 - For best results, soak for 8-48 hours.
 - Allow components to dry completely before reassembly.
 - A low to medium strength thread sealant is recommended when reassembling metal to plastic components.
 - Ensure injection tees are free from obstructions or leaks.
 - Clean Schrader valve:
 - Remove and lubricate valve core if significant debris is present.
 - Clean duckbill valve - soak in cleaning solution if significant chemical residue is present.
 - Thoroughly clean pressure relief valve. *See Repair Section VII. Cleaning Pressure Relief Valve.*
-

AFTER HEAVY USE

- Check tubing ends and cut off deeply scored, kinked, or obstructed tubing with a sharp, straight blade (such as box cutter or knife).
- Separate and soak injection tees, black push-to-connect tees, tubing segments, and harness connectors. Allow complete drying before reassembly or storage.
- Recommended to lubricate O-rings on pressure relief valve and male barb of harness connector and X-ring on bottle cap as needed and after thorough cleaning.
 - Recommended: Synthetic silicone

I. REPLACING SET SCREWS/TIGHTENING TIPS

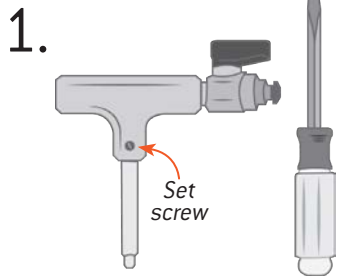

1. Loosen the set screw with flat head screwdriver.

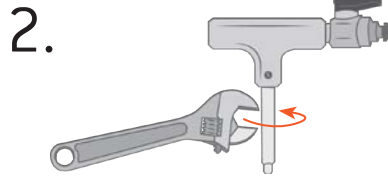

2. Use wrench to tighten the tip. Avoid over-tightening.

NOTE: If a threaded part will not turn in one direction, give it a slight turn in the opposite direction to loosen up the seal.

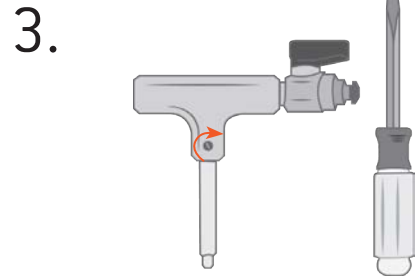

3. Re-tighten the set screw. Avoid over-tightening and stripping the screw.

II. REPLACING THE DUCKBILL VALVE

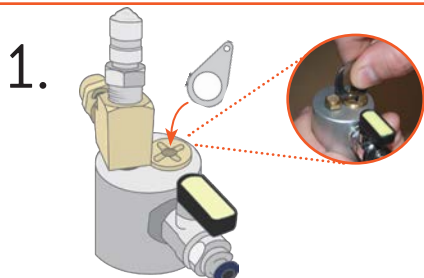

1. Use a coin or bottle top key (Field Repair Kit) to unscrew the brass valve plug.

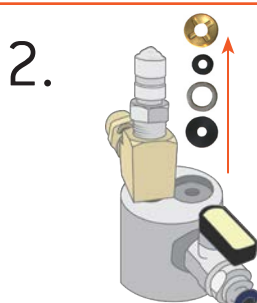

2. Remove the rubber grommet, metal shim, and retaining ring.

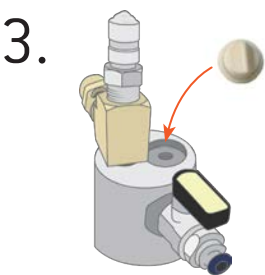

3. Remove the duckbill valve and replace it with a new one.

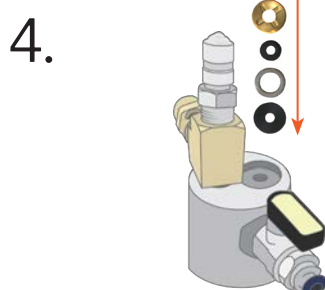

4. Replace the retaining ring first, then the metal shim, and the rubber grommet last.

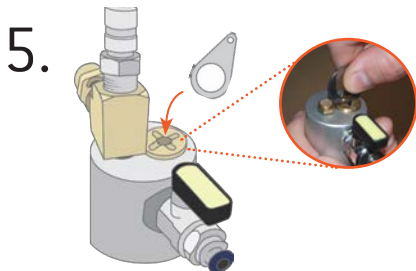

5. Replace the brass valve plug and tighten until hand-tight. DO NOT over tighten.

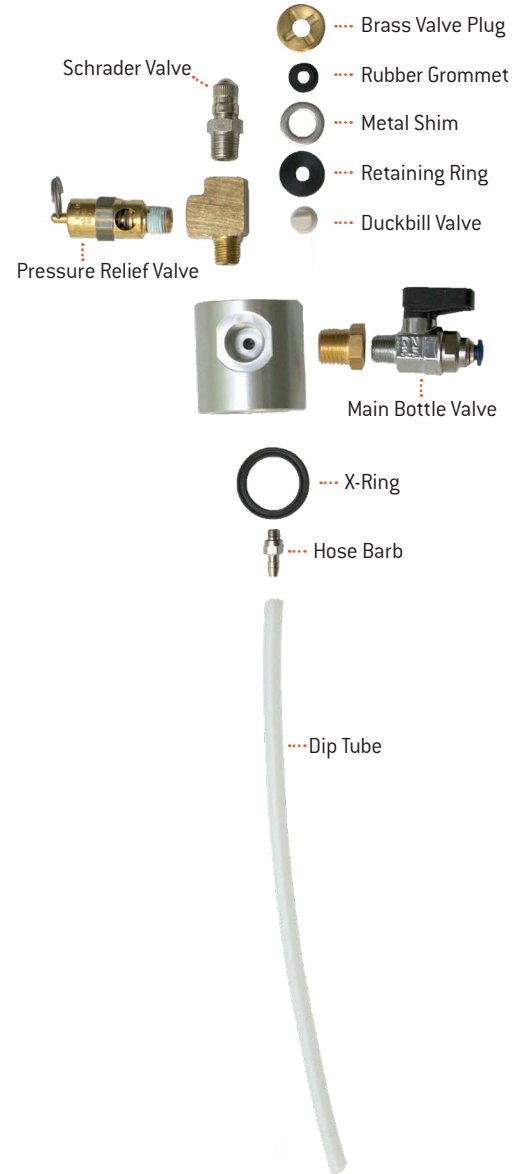

III. BLOCKING THE DOSING PORT

1.

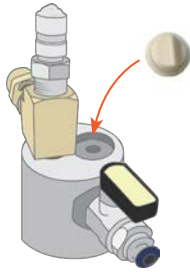

Follow steps 1 & 2 for replacing the duckbill valve.

2.

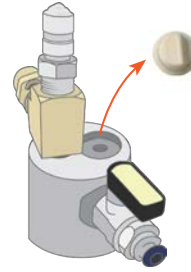

Remove duckbill valve if desired.

3.

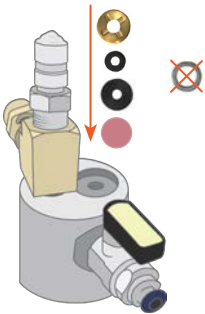

Place the rubber valve plug over the dosing port hole, then replace the retaining ring and rubber grommet. Do not use the metal shim.

4.

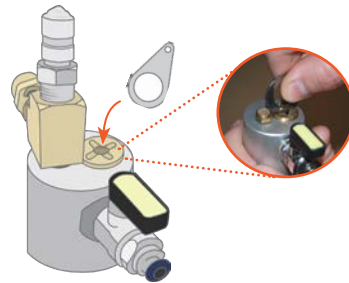

Replace the brass valve plug and tighten until hand-tight. DO NOT over tighten.

IV. REPLACING TUBING

1.

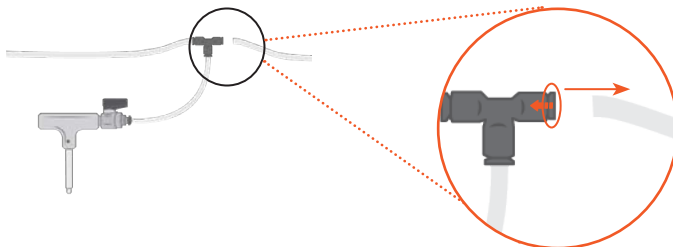

To disconnect tubing, push in the plastic collet of the push-to-connect and pull out the tubing.

2.



Replace damaged tubing with replacement sections in the field.

3.

Regularly inspect the tubing ends for chemical residue build-up, deep scoring, and kinks.

NOTE: Push-to-connect fittings are designed to score the tubing to hold it firmly in place. Over time, the scoring becomes deeper and can cause leaking with repeated connecting and disconnecting. Restore bad tubing ends by using a sharp box cutter, razor, or knife to make a straight, vertical cut past the damaged section. Do not use scissors or shears.

V. REPLACING BLACK PUSH-TO-CONNECT TEE

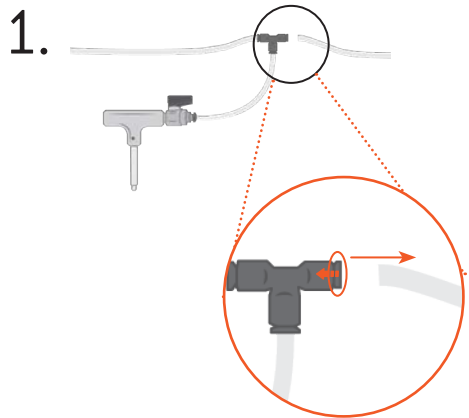

Remove tubing by pushing in and holding the collet, then pulling out the tubing.

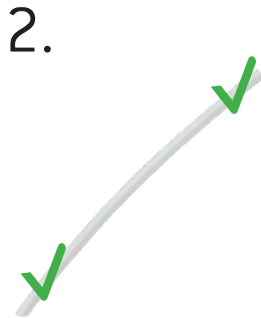

Ensure that tubing ends are in good condition.

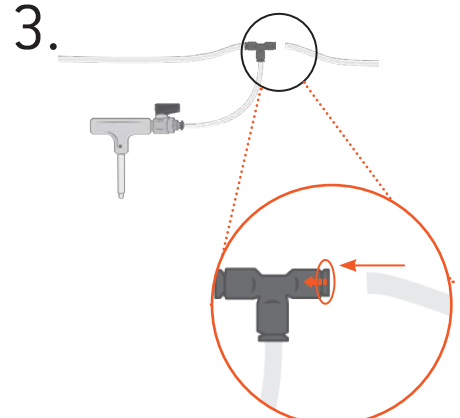

Switch faulty tee with replacement tee, making sure that tubing is inserted fully.

VI. REPLACING SCHRADER VALVE CORE

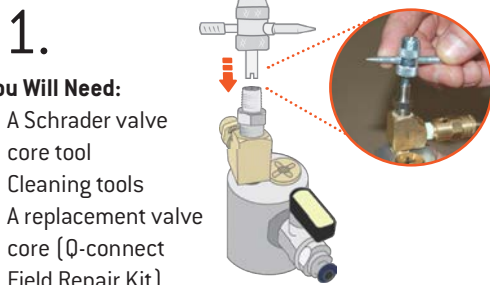

You Will Need:

- A Schrader valve core tool
- Cleaning tools
- A replacement valve core (Q-connect Field Repair Kit).

Use the core removal tool to unscrew the Schrader valve core.

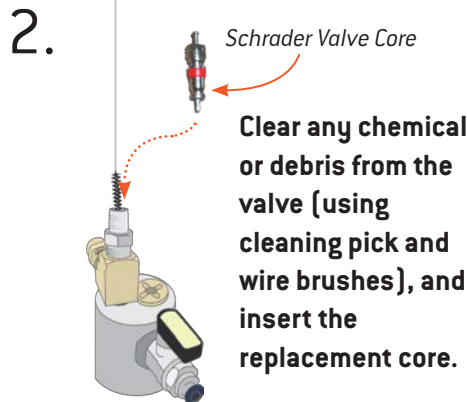

Schrader Valve Core

Clear any chemical or debris from the valve (using cleaning pick and wire brushes), and insert the replacement core.

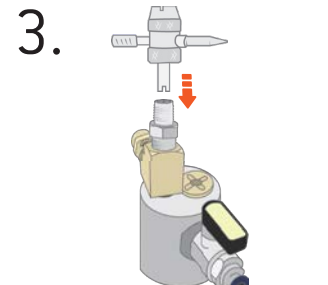

Retighten the Schrader valve core.

VII. CLEANING PRESSURE RELIEF VALVE

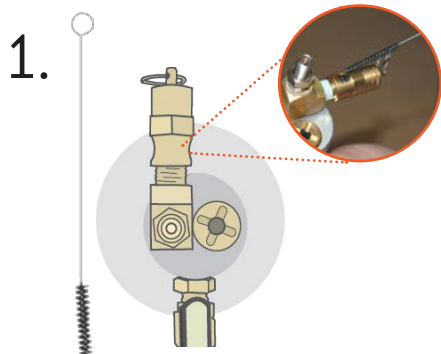

If pressure relief valve is not sealing (leaking air) or not opening when pressurized over 65 PSI, use wire brushes and pick with cleaning solution (isopropyl alcohol) to thoroughly remove residue and debris.

NOTE: It is important to keep the pressure relief valve functioning correctly to avoid potentially dangerous over-pressurization. Only use water or an isopropyl alcohol-based cleaning solution.

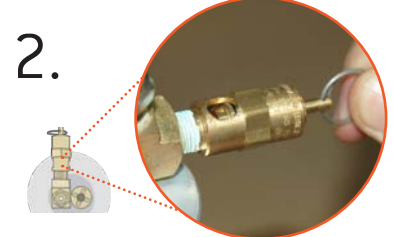

Add lubricant to the O-ring.

VIII. CLEANING HARNESS CONNECTOR

1.

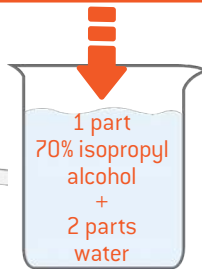
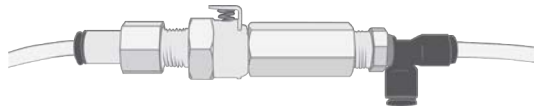

If harness connector is not connecting or is leaking, disconnect from tubing and clean thoroughly with a mixture of isopropyl alcohol and water.

2.



If problem persists, soak overnight in 70% isopropyl alcohol.

3.

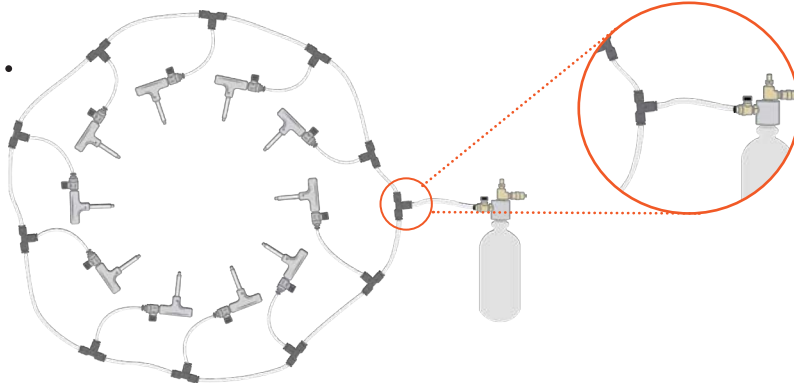

If the connector stops functioning in the field, remove the harness connector and connect both sides of the harness to a black push-to-connect tee that will feed directly from the bottle to finish the work. Clean or replace the harness connector.

IX. BOTTLE CAP MAINTENANCE

1.

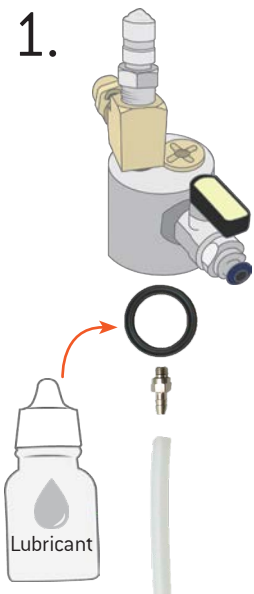

Add silicone lubricant to the X-ring.

2.



Inspect dip tube for obstructions.

3.

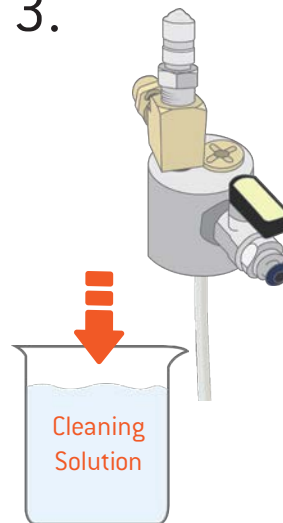

Clean away any residue or debris from components.

4.

If a component must be removed or replaced, it is recommended to re-seal the threads with pipe sealant or a medium strength thread lock product.



OUR GUARANTEE

Our products and services are guaranteed to give 100% satisfaction in every way - service, performance, quality, and value. If you are ever dissatisfied, in any way, please contact us so that we can address whatever concern you have. Our goal is your complete satisfaction.

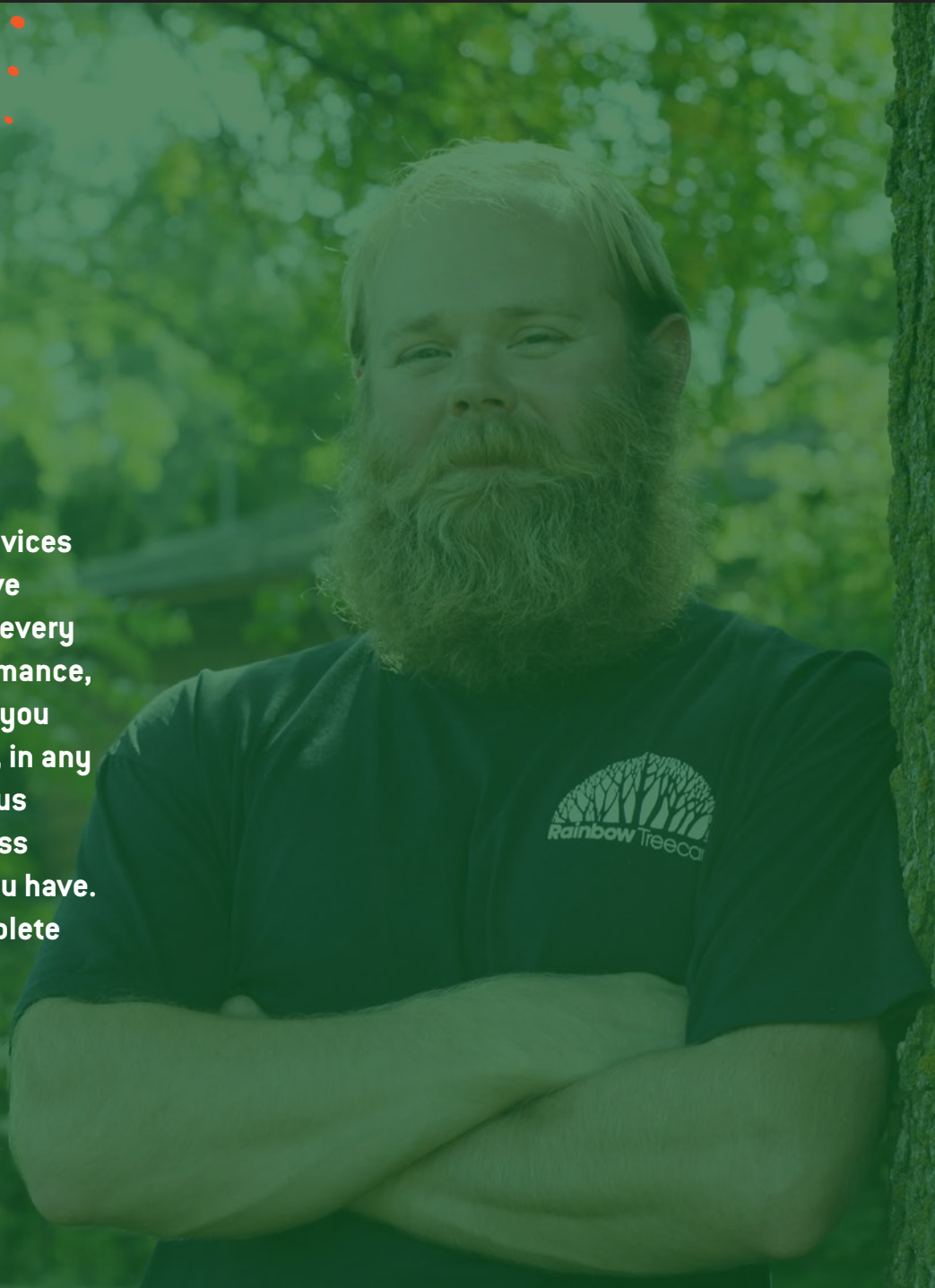

For tech support and protocols call **1-877-272-6747**
www.treecarescience.com • info@treecarescience.com



Digital Download of this Manual Available at: www.treecarescience.com/q-connect